

# P200

- **Linear steady state characteristics**  
*Lineare Kennlinie*
- **Integrated hydraulic accumulator**  
*Integrierter Druckspeicher*
- **Safe to run dry (liquid)**  
*Trockenlaufsicher (Flüssigkeit)*
- **Dry self-priming up to 2 meters depth, then self-priming up to 4 meters depth**  
*Trockenansaugend bis 2 Meter Tiefe, danach selbstansaugend bis 4 Meter Tiefe*
- **Liquid fertilizer-proof (UAN)**  
*Flüssigdüngertfest (AHL)*

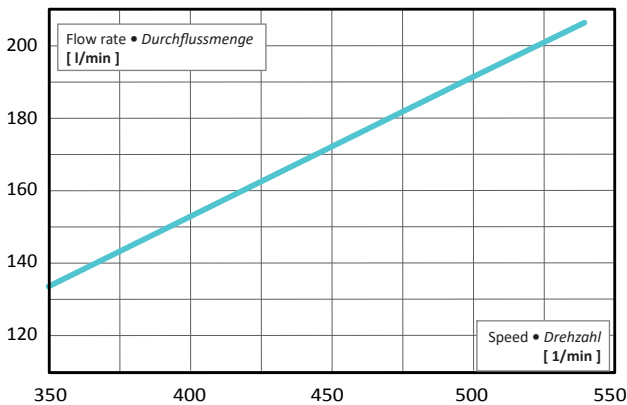

Capacity at 5 bar	Literleistung bei 5 bar	200 l/min
Article no.	Artikel-Nr.	82406*
Working diaphragms	Arbeitsmembrane	4 x NBR
Accumulator diaphragms	Druckspeichermembrane	1 x NBR
Inlet-Ø suction	Einlass-Ø Saugseite	AS50
Outlet-Ø pressure	Auslass-Ø Druckseite	AS30
Weight	Gewicht	28 kg

\* Setup with bracket and pto protection, including oil filling  
\* Aufbau mit Halterung und Schutztopf, inkl. Ölfüllung

Basic Parameters Eckdaten		
Nominal speed [rpm]	Nenn Drehzahl [U/min]	540
Speed range [rpm]	Drehzahlbereich [U/min]	450 — 600
Permanent pressure [bar]	Druck, auf Dauer [bar]	max. 15
Short-term pressure [bar]	Druck, kurzzeitig [bar]	max. 20
Spline shaft	Zapfwelle	DIN 9611 ISO 500
Lubrication: Oil bath		Schmierung: Ölbad
Materials: Cast aluminium, partially anodised, stainless steel, NBR seals, POM		Material: Aluminiumguss, teilweise eloxiert, Edelstahl, NBR-Dichtungen, POM

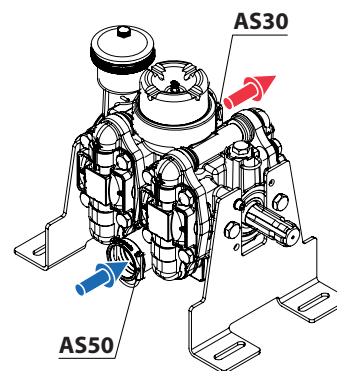

Power Consumption at 540 rpm Leistungsaufnahme bei 540 U/min	5 bar	10 bar	15 bar
	2,7 kW	4,4 kW	6,2 kW

- Options:  
Desmopan® Diaphragms  
Hydraulic drive  
Through shaft
- Sonderausführungen:  
Desmopan® Membranen  
Hydromotor  
Durchtriebswelle

Specifications in mm  
Angaben in mm

